



Dflow UV Liquid Applicator

Output range 0.100 to 1.00 litres per minute open flow

Installation instructions

The kit comprises:

*Pump unit with mounting bracket - Digital in-cab control box
Mounting brackets - Power cable - Tubing - Jet body and jets*

ALWAYS FLUSH WITH CLEAN WATER AFTER USE

A 3 way flushing valve is supplied for this

Please read the instructions in full and always follow the guidelines set out by the additive manufacturer with regard to safety, mixing and application rates.

DO NOT use with **SULPHURIC ACID** or **DIESEL**

Installation

Mount the pump unit in a secure location close to the additive container using the fixing points on the bracket

Mount the pump unit with the filter and outlets downward.

Attach the output of your tank to the inlet of the pump unit before the filter. **Use the 16mm O/D (larger) tube for this.** Note This should be no longer than 8ft (2.5M).

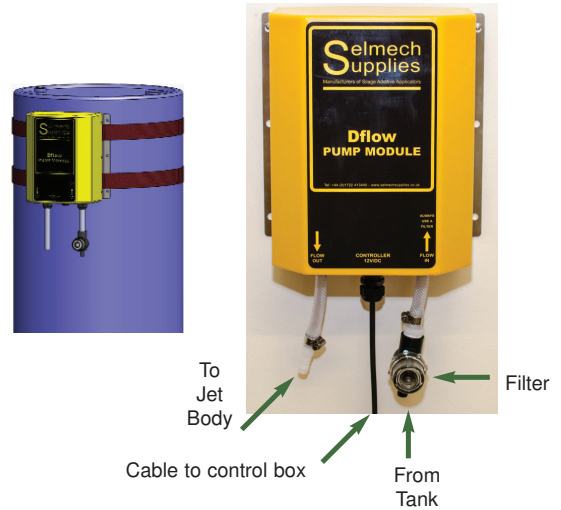

3 WAY FLUSHING VALVE

To maintain a clean system free of residual additive it is important to flush the applicator with clean water after use. A 3 way valve is supplied so that a container with clean water can be used to do this.

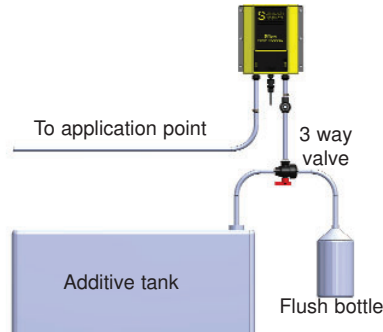

ALWAYS HAVE A FILTER IN PLACE BEFORE THE INLET TO THE PUMP

Soften the tube in hot water to help push on to the hose tails - Secure all pipes to tube tails with the clips provided.

Application point Use the 12mm O/D (smaller) tube for this.

The application point will depend on the machine you are fitting to. Typically for a forage harvester this would be the base of the chute behind the accelerator or over the feed rollers. Delivery of the additive can be open flow, or through a fan jet. Please note that if the application point is at the back of the blower of a self propelled harvester NO spray jet should be used as it would block easily, in this case application should be open flow.

If fitting to forage wagon or baler the application is normally delivered through 2, 3 or 4 jets either over the transfer rotor or over the pick-up reel.

Route the tubing from pump housing to the application point. Avoid sharp edges and hot spots and leave enough slack around and pivot points for turning.

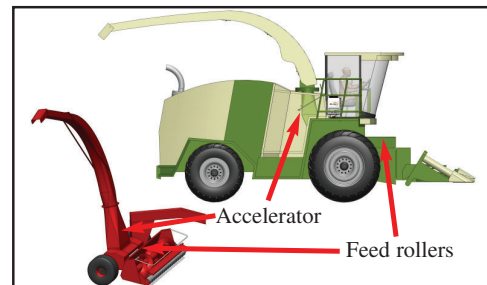
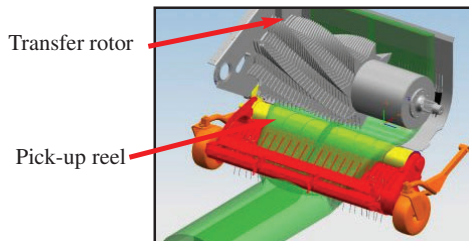

Fit the required jet to the jet body.

(Refer to setting the control box for harvesting section for flow rate setting)



Jet Selection

If using, jet selection is important to the performance of the applicator. Each jet provides a 110 degree spray pattern but it is important to use the correct jet for the output required to achieve the optimum spray pattern. If the output is pulsing on and off, fit a smaller jet to increase the pressure. If the jet is too small for a high output requirement the output will not be achieved and the control box will display check flow. The pump has a pressure release valve and if the pressure gets too high this may turn the pump off. If this happens release the pressure and fit a bigger jet or an additional jet body.

We do not recommend ULTRA LOW application rates be used on balers or forage wagons.

The table below should be used as a guide to jet selection.

SINGLE JET litres per minute	
GREEN	RED
0.1 - 0.60	0.50 - 1.20

TWIN JET litres per minute	
GREEN	YELLOW
0.5 - 0.7	0.7 -1.20

Applicator care and maintenance

The system should be flushed through with clean water after use.

The motor must be kept dry, avoid damage to wiring and pipe work.

If you suspect a blockage in the system the following components should be cleaned.

Cleaning the Strainer

The strainer should be cleaned at the end of each season or if a blockage is suspected.

1. Unscrew filter assembly from pump
2. Unscrewing the clear bowl and removed the filter gauss.
3. Clean the gauss, body and bowl in clean water
4. Re-assemble and re-fit.

Flow Sensor Cleaning

Remove the pump chamber cover .

Undo the jubilee clips each side of the flow sensor and remove pipes. Do not strain the cable.

Separate the two halves of the sensor body by removing the 4 socket cap screws.

Although robust when separated the great care should be taken with the flow sensor impeller.

Gently lift out the impeller and thoroughly clean the in-put and out-put ports of the internal chamber.

Once clean, reassemble, Note that the impeller has 3 magnets molded into it. One side the faces a slightly bigger diameter. This is the side that goes down onto the half with the cable. Make sure the impeller seats into its centre bearing in both top and bottom halves.

Check that the impeller spins by blowing into the inlet side of the flow sensor. You should hear it spin. If it does re-fit the 4 M3 screws and nuts and gently tighten. Check again that the impeller spins as before.

At no time should an air line be used on the flow sensor!

Refit the pipes and tighten jubilee clips.

Refit cover by hooking the tab on the top over the bracket. Angle the cover and push over the lower bulkhead. Refit screws.

Control box.

The control box has a 10amp fuse.

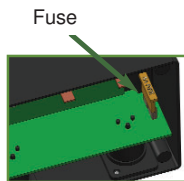

Fault finding

Refer to the control box user manual for instruction on how to enter diagnostic mode. They can be vey helpful in helping to identify the cause of problems.

If the control unit appears to working but pump is not running.

Unplug the power and pump leads and connect them together to check the pump.

(If the pump runs when this is done but not when the control box is connected it is possible to carry on using the applicator in this mode. The pump will run at maximum out put so an adjustment to the additive mix will be necessary to achieve the correct application rate.)

If the pump runs at full or fixed speed regardless of flow setting.

Clean the flow sensor

Erratic operation and Display light flickers.

Check power supply is adequate.

If "CHECK FLOW" is displayed frequently it could mean there is a fault in the system.

Check the continuity of the cable particularly the Green/Yellow wire from the tag board in the applicator to the 3 pin plug at the control box.

Use the "Diagnostic Mode" to check if pulses are being detected from the flowsensor when the pump is running.

Pump unit

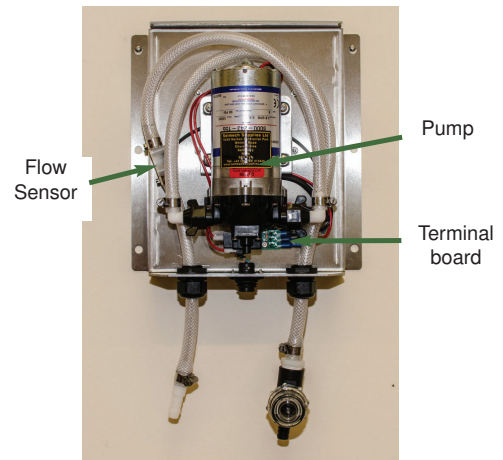

Flow out

Flow in
*Always fit filter
before input*

Pump Strainer



Flow sensor

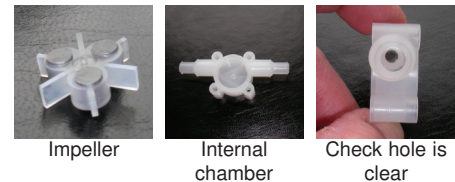

Angle cover
to refit



Pump test

Connect the power and pump leads together to check if the pump runs independently of the control unit.



Warranty All Selmech Supplies applicators are guaranteed against failure which can be attributed to faulty workmanship for a period of six months from date of delivery.

Connection schematic diagram

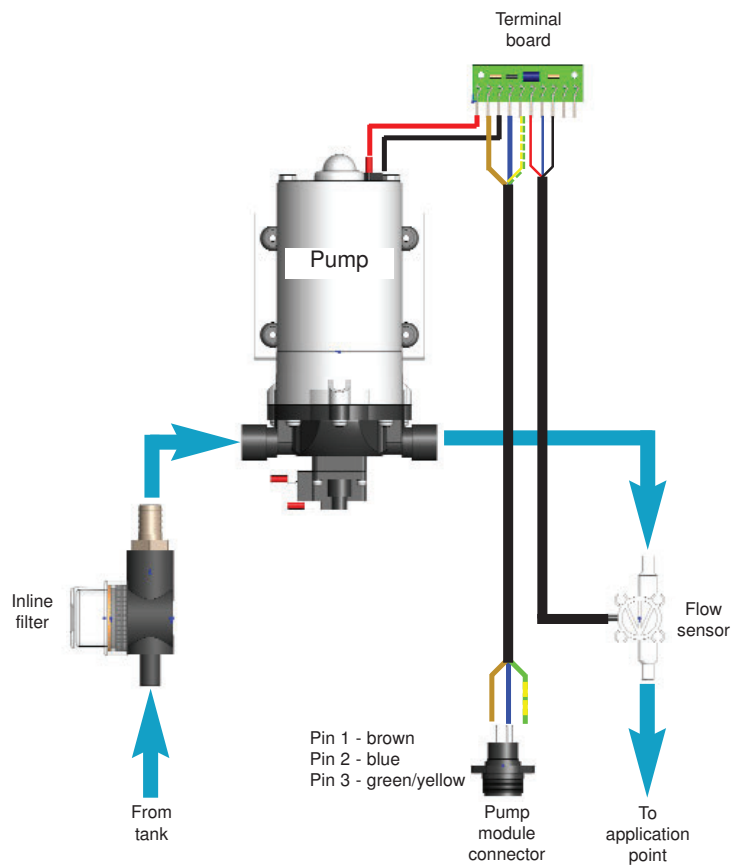
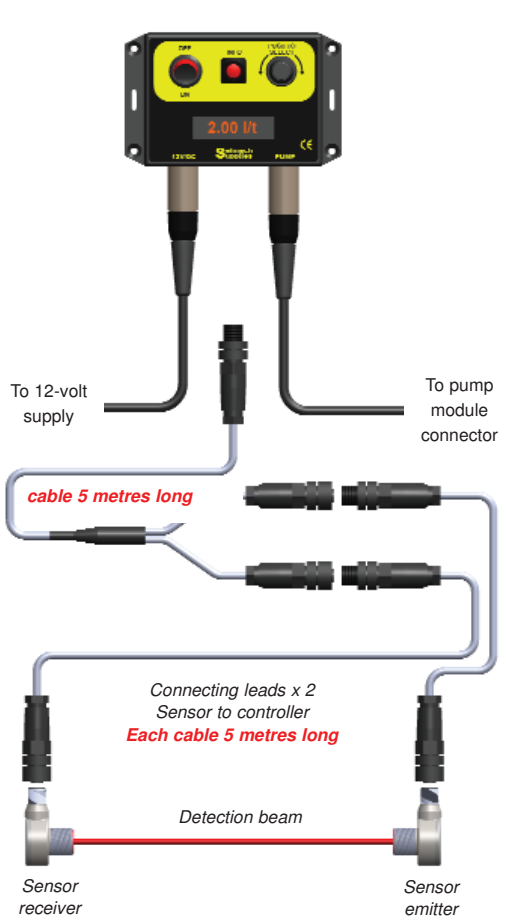

Crop detector installation

The photoelectric sensors should be mounted so that they look across the point where you want the swath to be detected. For example at the point of the pick-up where the swath is transferred into the baler/forage wagon. There are two mounting brackets supplied. The sensor has a visible red beam to help alignment.

Terminal board connections

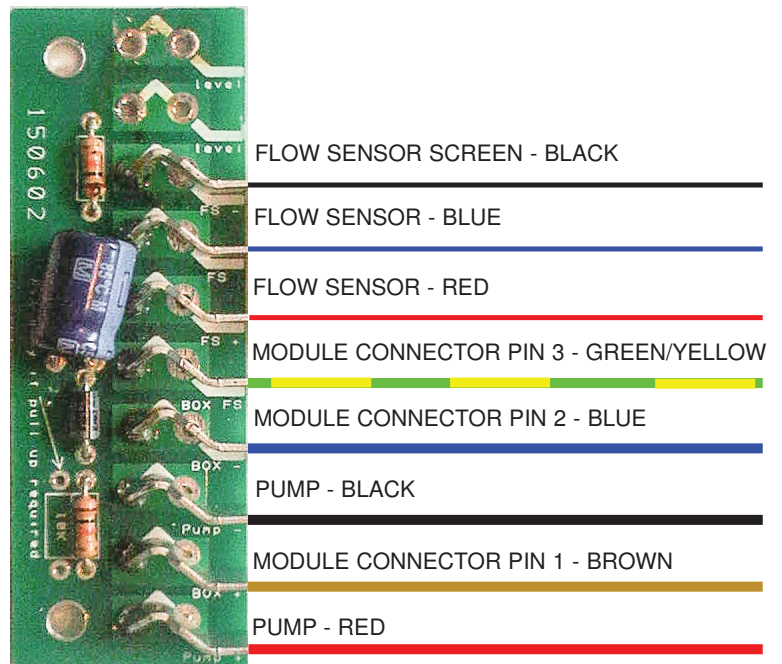

3 WAY FLUSHING VALVE

To maintain a clean system free of residual additive it is important to flush the applicator with clean water after use. A 3 way valve is supplied so that a container with clean water can be used to do this.

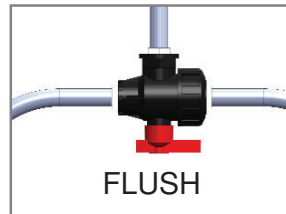
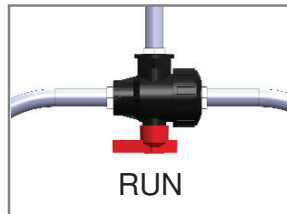
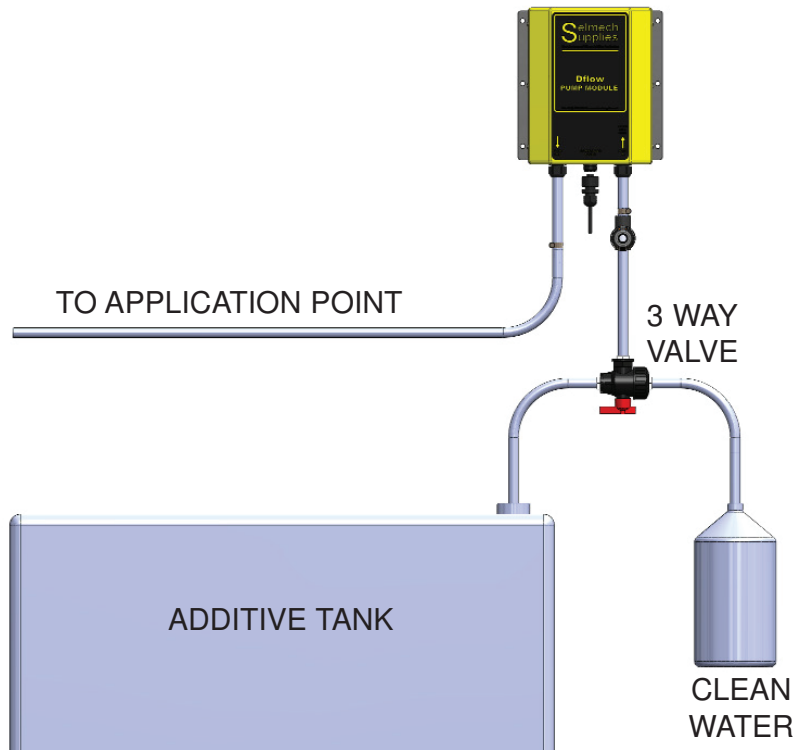

Turn the tap lever in the direction you want to draw from

Diaphragm Pump

TROUBLESHOOTING

PUMP WILL NOT START:

- ✓ Fuse or breaker
- ✓ For correct voltage ($\pm 10\%$) and electrical connections
- ✓ Pressure switch operation and correct voltage at switch or motor wires (as equipped).
- ✓ Rectifier or motor for open or grounded circuit
- ✓ For locked drive assembly

WILL NOT PRIME: (No discharge/motor runs)

- ✓ Out of product
- ✓ Strainer for debris
- ✓ Inlet tubing/plumbing; severe vacuum leak
- ✓ Inlet/Outlet tube severely restricted (kinked)
- ✓ Debris in pump inlet/outlet valves
- ✓ Proper voltage with the pump operating ($\pm 10\%$)
- ✓ Pump housing for cracks

LEAKS FROM PUMP HEAD OR SWITCH:

- ✓ For loose screws at switch or pump head.
- ✓ Switch diaphragm ruptured or pinched
- ✓ For punctured diaphragm if fluid is present at bottom drain holes.

PUMP WILL NOT SHUT-OFF: (Pressure switch equip.)

- ✓ Output line closed and no leaks
- ✓ For air trapped in outlet line or pump head
- ✓ For correct voltage to pump ($\pm 10\%$)
- ✓ Inlet/Outlet valves for debris or swelling
- ✓ For loose drive assembly or pump head screws
- ✓ Pressure switch operation/adjustment incorrect refer to S/B #1031 for differential and pressure adjustment procedure

NOISY / ROUGH OPERATION:

- ✓ Mounting feet that are compressed to tight
- ✓ For loose pump head or drive screws
- ✓ Does the mounting surface multiply noise (flexible)
- ✓ Is the pump plumbed with rigid pipe causing noise to transmit

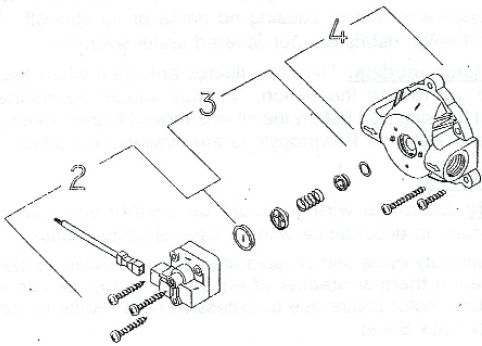

SERVICE KITS

Kits are readily available to repair standard 8000 series pumps. Repair kits include simple illustrated instructions allowing easy installation. To insure that the correct kit is received the model numbered and all name plate data must be included with the order. Contact a SHURflo distributor or SHURflo directly to order the necessary repair kit.

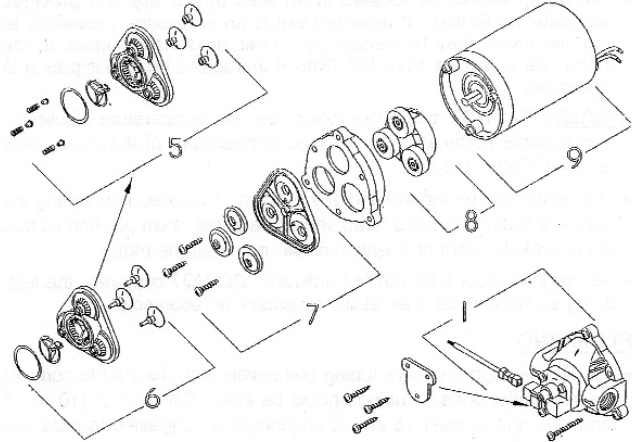

KEY#	DESCRIPTION
1	Complete assembled pump head
2	Pressure switch assembly
3	Check valve components
4	Upper housing
5	Bypass valve and discharge valve assembly
6	Valve plate assembly
7	Diaphragm and piston components
8	Drive assembly
9	Motor assembly (less base plate)

Fault	Diagnosis	Remedy
Motor will not run	Wire incorrectly connected or damaged	Check power connection
		Check control box wires.
Motor runs but no output	Fuse blow	There is a fuse inside control box. If blown relace and check for reasons for blown fuse before restarting.
	Defective motor	Contact Selmech Supplies.
	Jet blocked	Clean jet
Motor runs but poor output	Tubing kinked	Remove kink and re-route tubing
	Strainer blocked	Clean Strainer
	Jet blocked	Clean
	Jet too small	Replace with larger jet
	Tubing kinked	Remove kink and re-route tubing
"CHECK FLOW" displayed constantly	Tube split	Replace tube
	Barrel empty	Fill barrel or replace
	Wrong application rate	Re-calibrate
	Damaged or broken cable	Check the continuity of the cable particularly the Green/Yellow wire from the tag board in the applicator to the 3 pin plug at the control box. Use the "Diagnostic Mode" to check if pulses are being detected from the flowsensor when the pump is running. <i>see controller user guide</i>

DFLOW MODULE PARTS LIST

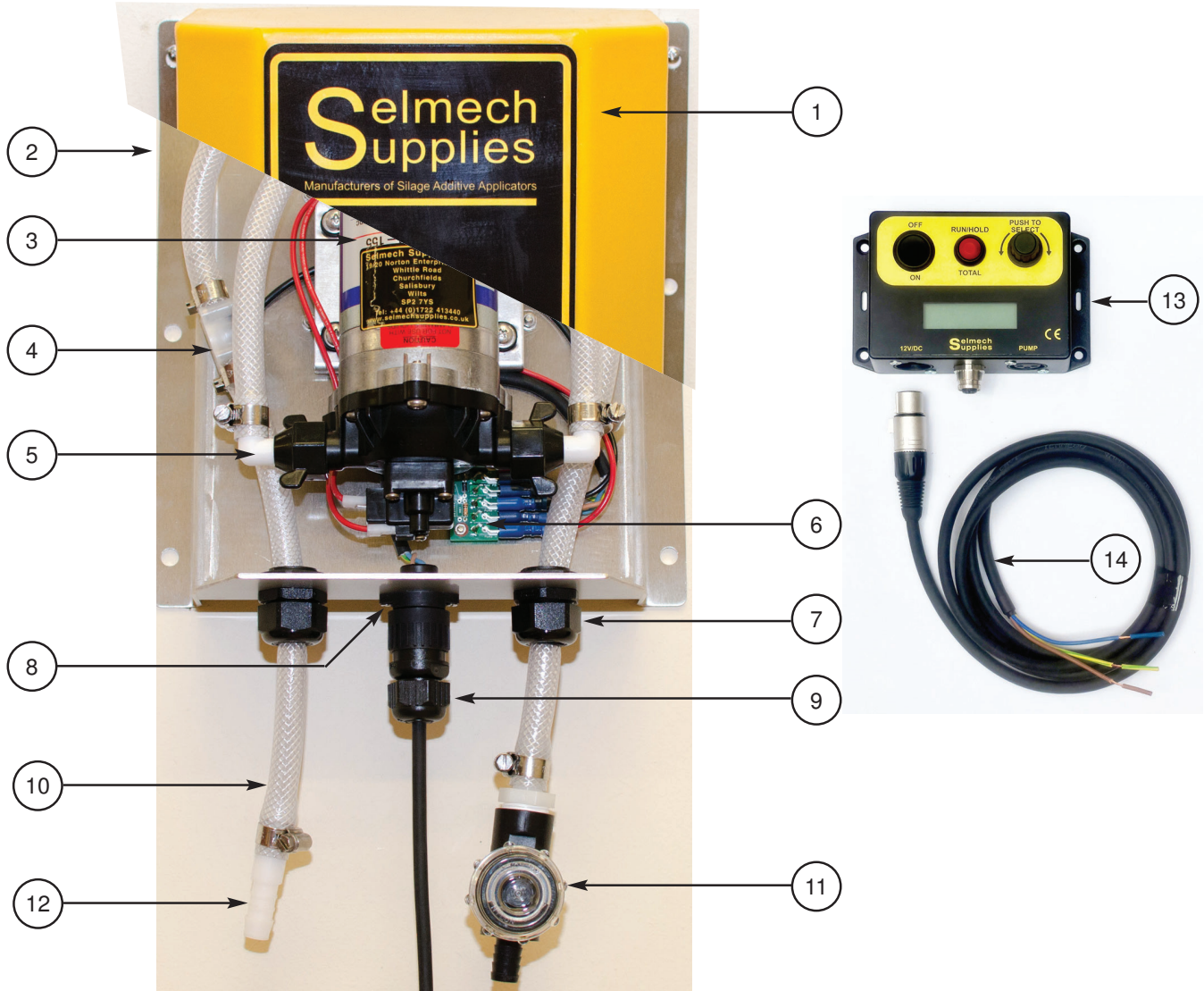

ITEM NO.	DESCRIPTION	QTY
1	MODULE COVER	1
2	MODULE BRACKET	1
3	PUMP UV (542-250 1.2 l/m - LV (243-155) 5l/m - HV (514-145) 10l/m	1
4	FLOW SENSOR UV 1.2l/m - LV 5 l/m - HV 10 l/m	1
5	HOSE TAIL	2
6	TAG BOARD	1
7	HOSE CLAMP	2
8	4 WAY MALE CHASSIS MOUNT CONNECTOR WITH CABLE	1
9	SIGNAL CABLE TO CONTROLLER (8M)	1
10	10MM I/D 16MM O/D BRAIDED HOSE	1.6M
11	IN-LINE BOWL FILTER	1
12	IN-LINE HOSE TAIL	1
13	OSD CONTROLLER	1
14	POWER LEAD	1

Conversion Chart

Approximate US to Metric Equivalents

Pounds to Kilograms

Bale weight in Pounds	Bale weight in Kilograms
Small Bales	
45	20
66	30
88	40
110	50
Big Bales	
400	180
600	270
800	360
1000	450
1200	540
1400	630
1600	700
1800	800
2000	900
2200	1000
2400	1100
2600	1180
2800	1270
3000	1360

Ounces to Grams

Ounces per Ton	Grams per ton
1	30
1.4	40
1.8	50
2	60
2.5	70
2.8	80
3.2	90
3.5	100
3.8	110
4.2	120
5	140
6	170
7	200
8	230
9	260
10	280
11	310
12	340
13	370
14	400
15	420
16	450
17	480
18	500

Fluid Ounces to Millilitres

US fluid Ounces	Millilitres
0.3	10
0.6	20
1.0	30
1.3	40
1.6	50
2.0	60
2.3	70
2.6	80
3.0	90
3.3	100
3.6	110
4.0	120
4.3	130
4.6	140
5.0	150
5.3	160
5.6	170
6.0	180
6.3	190
6.6	200
7.0	210
7.3	220
7.6	230
8.0	240